

5,800-CUBIC-FOOT COVERED HOPPER

LIGHT-DENSITY BULK PRODUCTS



This versatile car is re-engineered to increase capacity, incorporating the latest design and manufacturing techniques for a high-quality, reliable railcar.

It features FreightCar America's patent pending fabricated center sill, one-piece longitudinal hood, welded curved side and curved roof. This car also incorporates industry-standard trough hatches and discharge gates.

MULTIPLE TROUGH COVER AND GATE OPTIONS AVAILABLE TO MEET SPECIFIC LOADING AND UNLOADING NEEDS.

FREIGHTCAR AMERICA'S Covered Hopper products are purpose-built to offer reliable and productive heavy-haul transportation options tailored to your needs.

FREIGHTCARAMERICA.COM

5,800-CUBIC-FOOT COVERED HOPPER

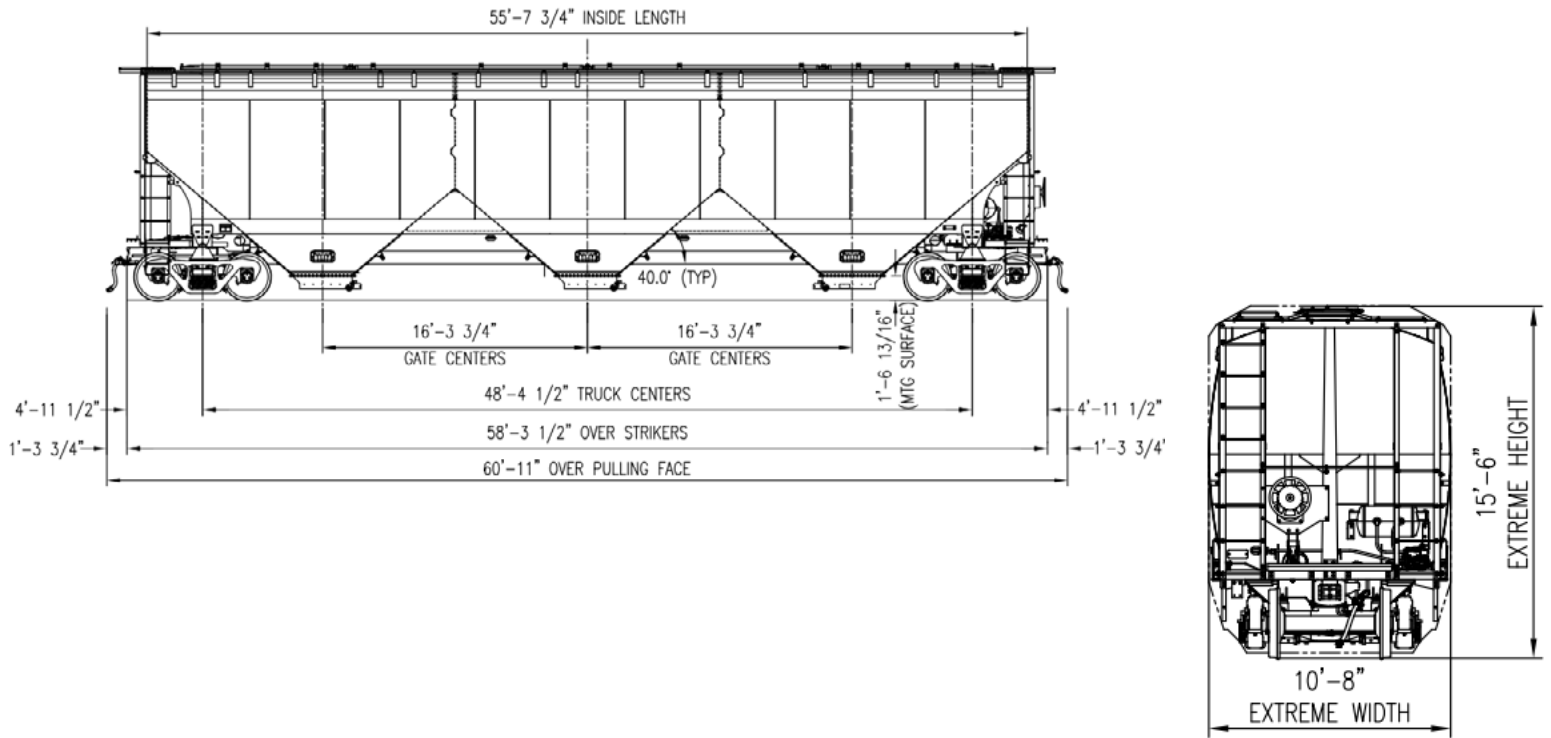

GENERAL DIMENSIONS

LENGTH	Inside	55' 7-3/4"
	Over Strikers	58' 3-1/2"
	Over Pulling Face of Free Couplers	60' 11"
	Truck Centers	48' 4-1/2"
WIDTH	Inside	10' 6-3/4"
	Extreme	10' 8"
HEIGHT	Extreme	5' 1"
CAPACITY/ WEIGHTS	Cubic Capacity	5,800 cu. ft.
	Lightweight	62,400 lbs.
	Gross Rail Load	286,000 lbs.
	Load Limit	223,600 lbs.
	Center of Gravity, Loaded, with Cover	98.0"